

E-Power Pump

HIGH PERFORMANCE & HEAVY DUTY
For residential and semi-commercial pools



 **Emaux**
water technology



RoHS
COMPLIANT
2002/95/EC



SAA

Pool & Spa Equipment

SIGNATURE COLLECTION

Product Features

- 1) Asynchronous, Two poles motor
- 2) Class insulation: 130(B)
- 3) IPX5 Waterproof standard
- 4) Built-in thermal protection
- 5) Overload protection
- 6) Available in 50Hz or 60Hz with 220V/380V
- 7) Special design union compatible for both imperial and metric measurement standard
- 8) Imperial and Metric measurement standard
- 9) S.S 316 Shaft
- 10) S.S 316 Mechanical seal
- 11) Self-Priming up to 2.5m above water level
- 12) Testing pressure 50 PSI (3.5 Bar)
- 13) Basket Volume 5 litres

Ring lock seal design eliminate suction leaks and maximize suction efficiency



An Excellent Self-Priming Pump



Technical Information

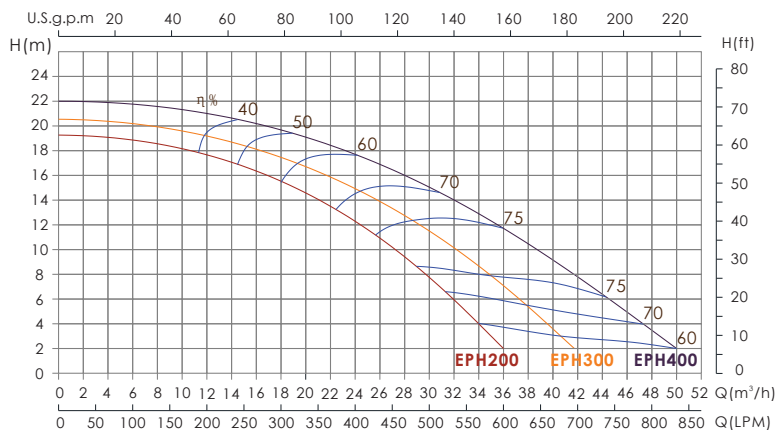

Remark: The performance curve above is for 50Hz models.

Model 50Hz	Input (kW)	Current (AMP)	Noise (dB)	Head (m)					
				6	8	10	12	14	16
Flow Rate (m³/h)									
EPH200	1.8	8.2	68	32	30	27	24	21	17
EPH300	2.2	10.0	69	37	35	32	29	26	22
EPH400	2.8	12.5	71	45	42	39	36	32	28

Product Dimension

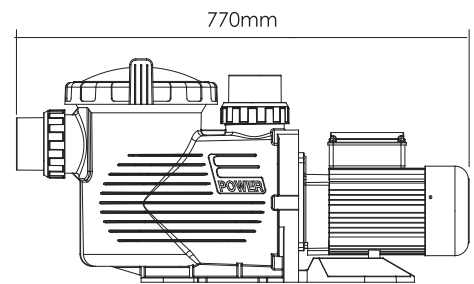
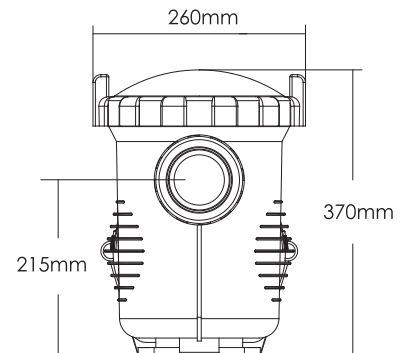

Code 220V/50Hz	Code 220V/60Hz	Code 380V/50Hz	Model	Connection Size	Horsepower	Weight(kg)
88020708	88021008	88020808	EPH200	2" / 63mm 2.5" / 75mm	2.0hp	23.0
88020709	88021009	88020809	EPH300	2" / 63mm 2.5" / 75mm	3.0hp	24.0
88020718	88021018	88020818	EPH400	2" / 63mm 2.5" / 75mm	4.0hp	25.0